

Pinkwood PKjoists®

Grouped Holes larger than 1-1/2" - Analysis

How to analyze holes cut too close together

The allowance of multiple field cut holes in PKjoists® is known and guidelines are published in both the specifiers guide, the installation guide, and in the current code evaluation report. The approved allowance of 2 times the greater dimension of the largest hole is as shown below:

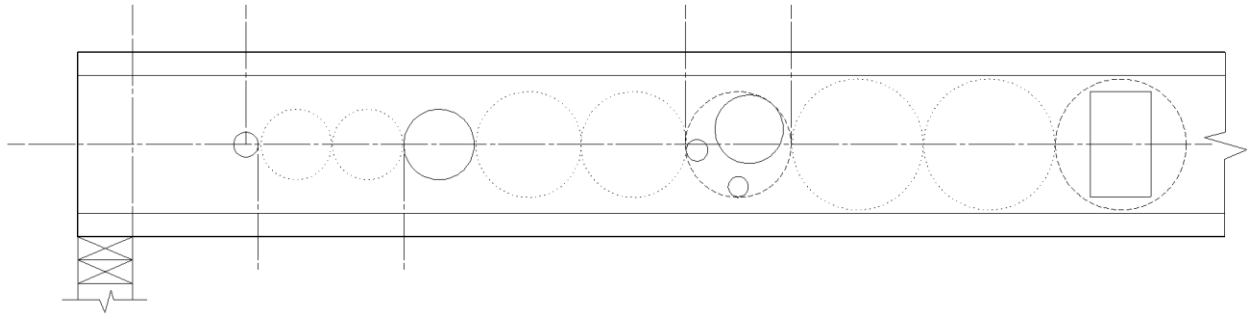

For clustered round holes, as shown above, the circumscribed larger encompassing method can assist in evaluating if the theoretical “larger hole” is still allowed within a given location. Circumscribed rectangular or polygonal holes may also be allowed provided they fall within the allowable location of the theoretical “larger hole”.

Allowable software analysis

For analyzing hole allowances for grouped circumscribed holes, rectangular holes, and holes in joists with unique loading conditions, both CSD® (Calculated Structural Design) software and Sapphire® by MiTek utilize the published web shear capacity of the PKjoist® listed in the code evaluation report. When properly analyzed, if the hole or circumscribed larger hole “passes” the web shear check, the actual web hole condition does not need to be repaired or reinforced.

Holes greater than 1-1/2-inch in diameter and which fall outside of the above listed guidelines may need to be reviewed by a licensed design professional prior to acceptance by Pinkwood Ltd.

If you have any questions, please contact Pinkwood Ltd. for details.

